

Pump HT210/200

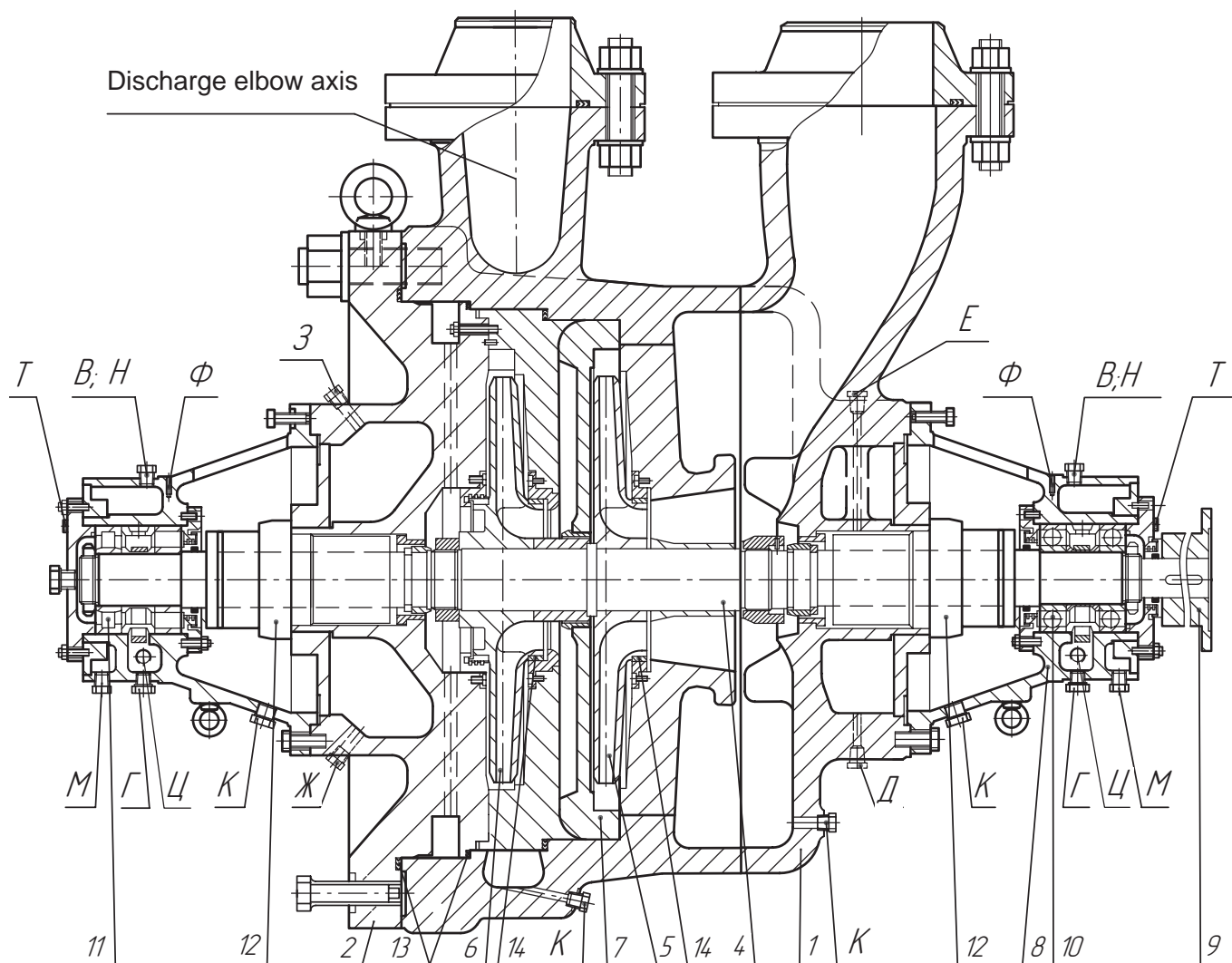

- | | |
|---------------------------|--|
| 1. Pump casing; | 9. Half-clutch; |
| 2. Pump cover; | 10. Radial-thrust ball bearing (ball); |
| 4. Shaft; | 11. Rolling radial bearing; |
| 5. First stage impeller; | 12. Shaft sealing; |
| 6. Second stage impeller; | 13. Spiral-wound gaskets; |
| 7. Pump diffuser; | 14. Sealing rings (rotary). |
| 8. Bearing housing; | |

Performance of pump HT210/200

$n = 1475 \text{ rev/min}$ $\nu = 0,01 \text{ cm}^2/\text{s}$ $\rho = 1000 \text{ kg/m}^3$

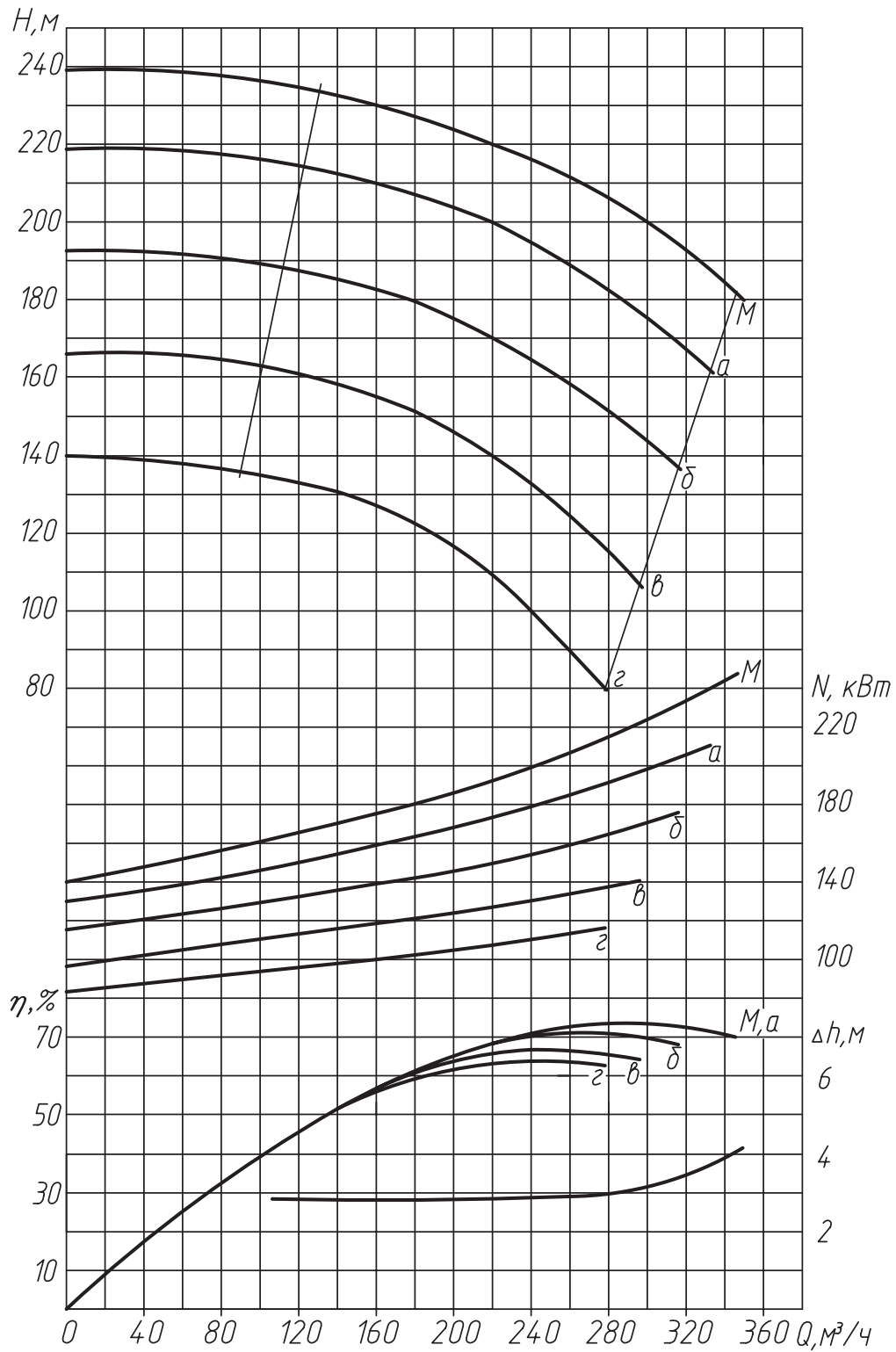

Outline drawing of pump HT210/200

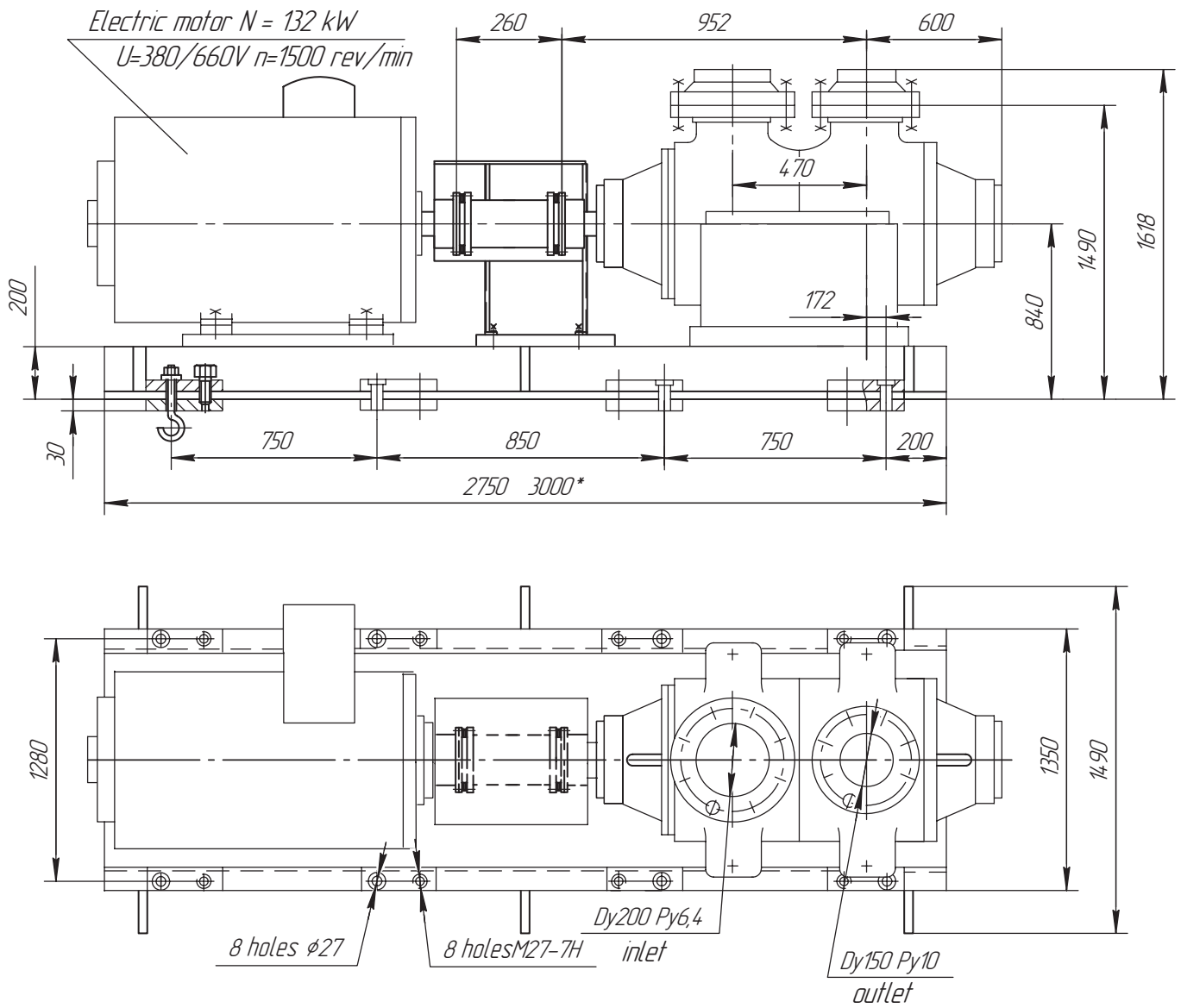

* Dimensions for electric motor $N = 160 - 250 \text{ kW}$ $n = 1500 \text{ rev/min}$