

# Pump HKB600/320

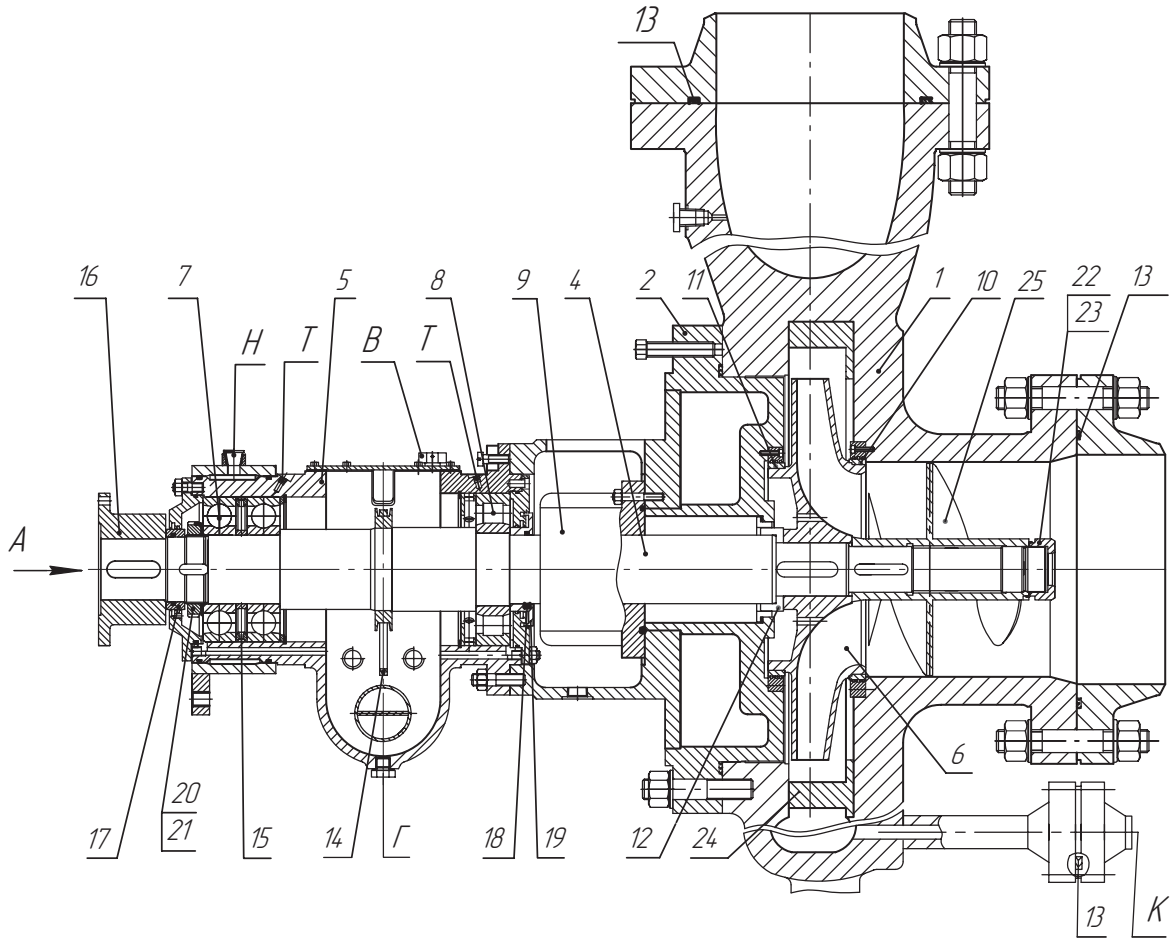

- |                                 |                              |
|---------------------------------|------------------------------|
| 1. Pump casing;                 | 14. Oil supply ring;         |
| 2. Pump cover;                  | 15. Complete set of washers; |
| 4. Shaft;                       | 16. Halfcoupling;            |
| 5. Bearing housing;             | 17. Barrel;                  |
| 6. Impellers;                   | 18. Seal rings;              |
| 7. Radial-thrust ball bearings; | 19. Baffle ring;             |
| 8. Rolling radial bearings;     | 20-21. Nut-washer;           |
| 9. Shaft sealing;               | 22-23. Nut-washer (rotary).  |
| 10-11. Sealing rings (rotary);  | 24. Pump diffuser            |
| 12. Barrel;                     | 25. Twisted gear             |
| 13. Spiral-wound gaskets;       |                              |

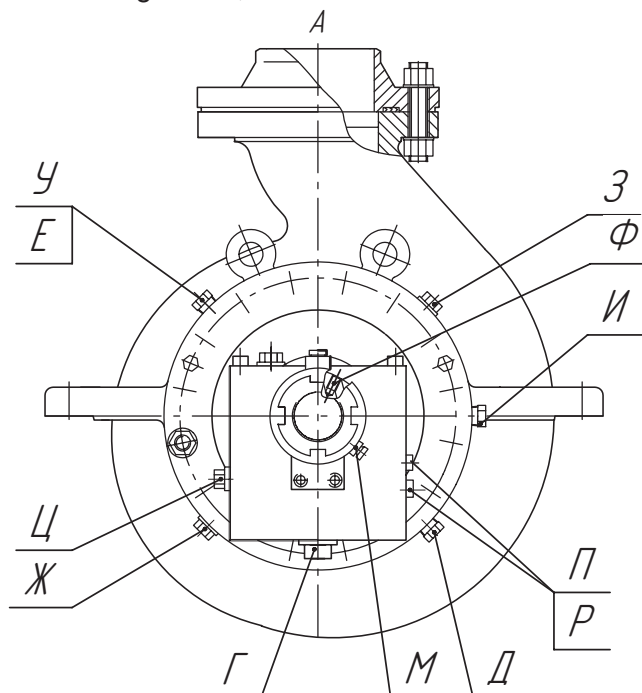

# Performance of pump HKB600/320

$n = 2950 \text{ rev/min}$   $\nu = 0,01 \text{ cm}^2/\text{s}$   $\rho = 1000 \text{ kg/m}^3$

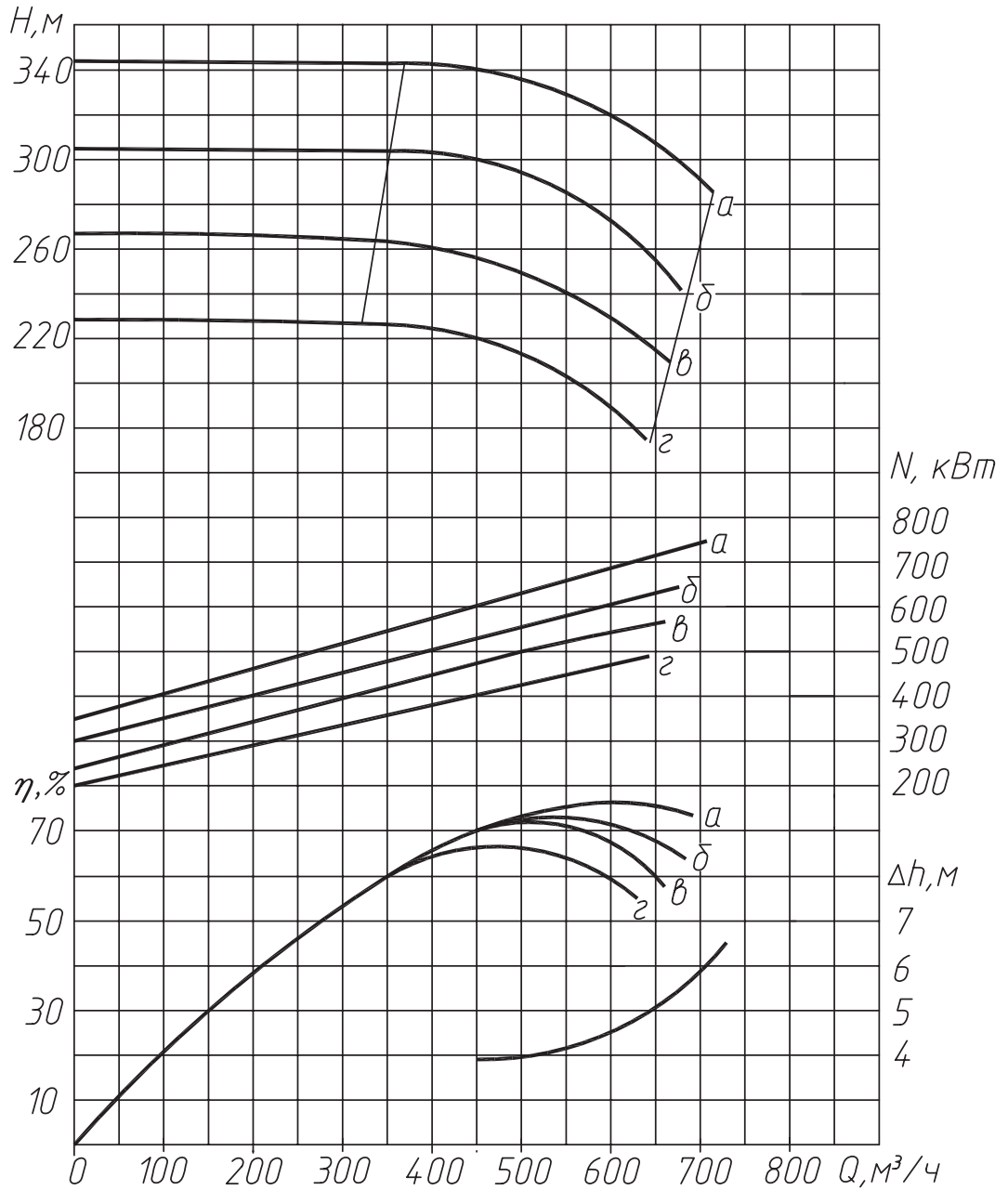

# Performance of pump HKB600/320

$n = 1475 \text{ rev/min}$   $\gamma = 0,01 \text{ cm}^2/\text{s}$   $\rho = 1000 \text{ kg/m}^3$

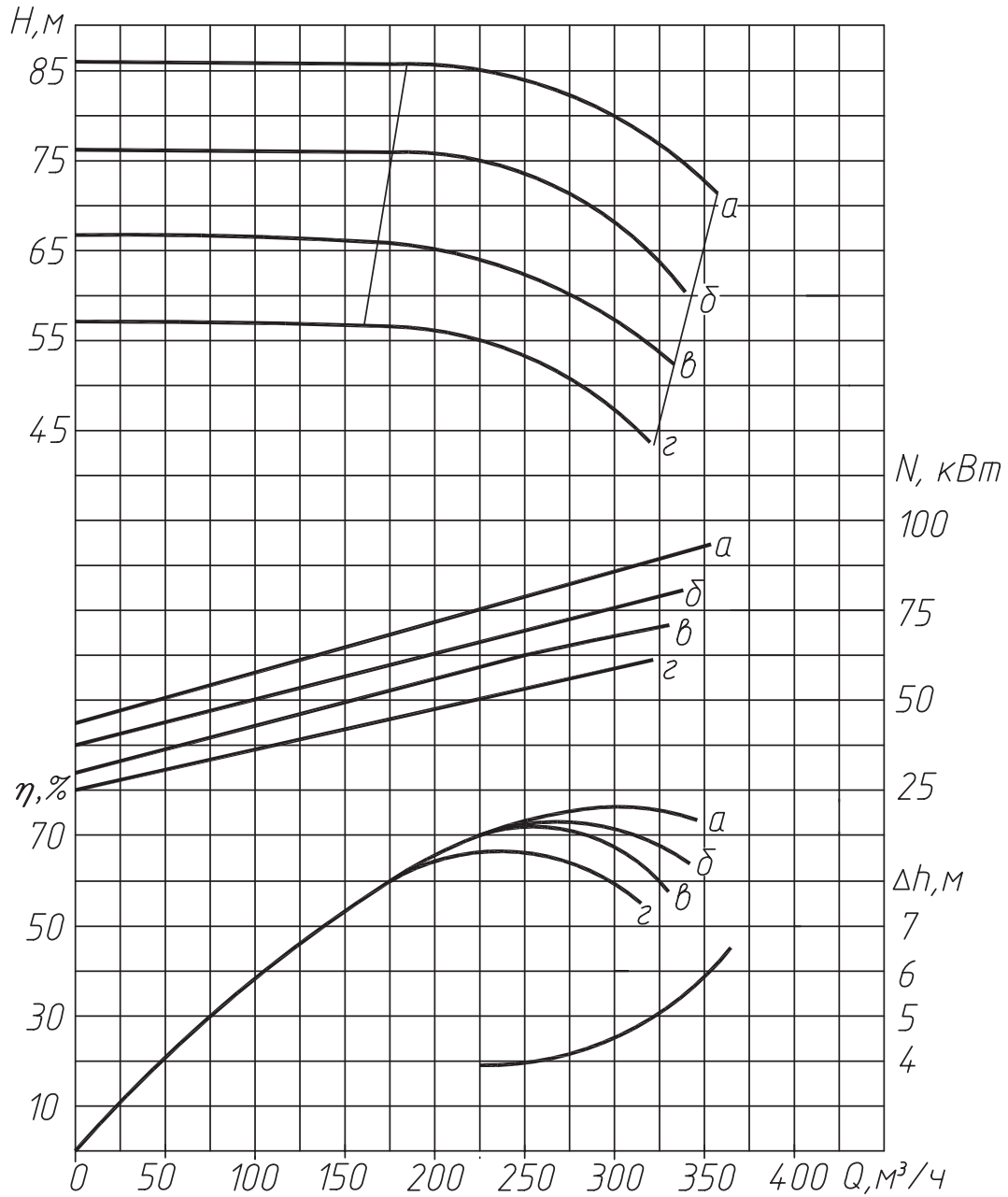

## Outline drawing of pump HKB600/200 Welded frame

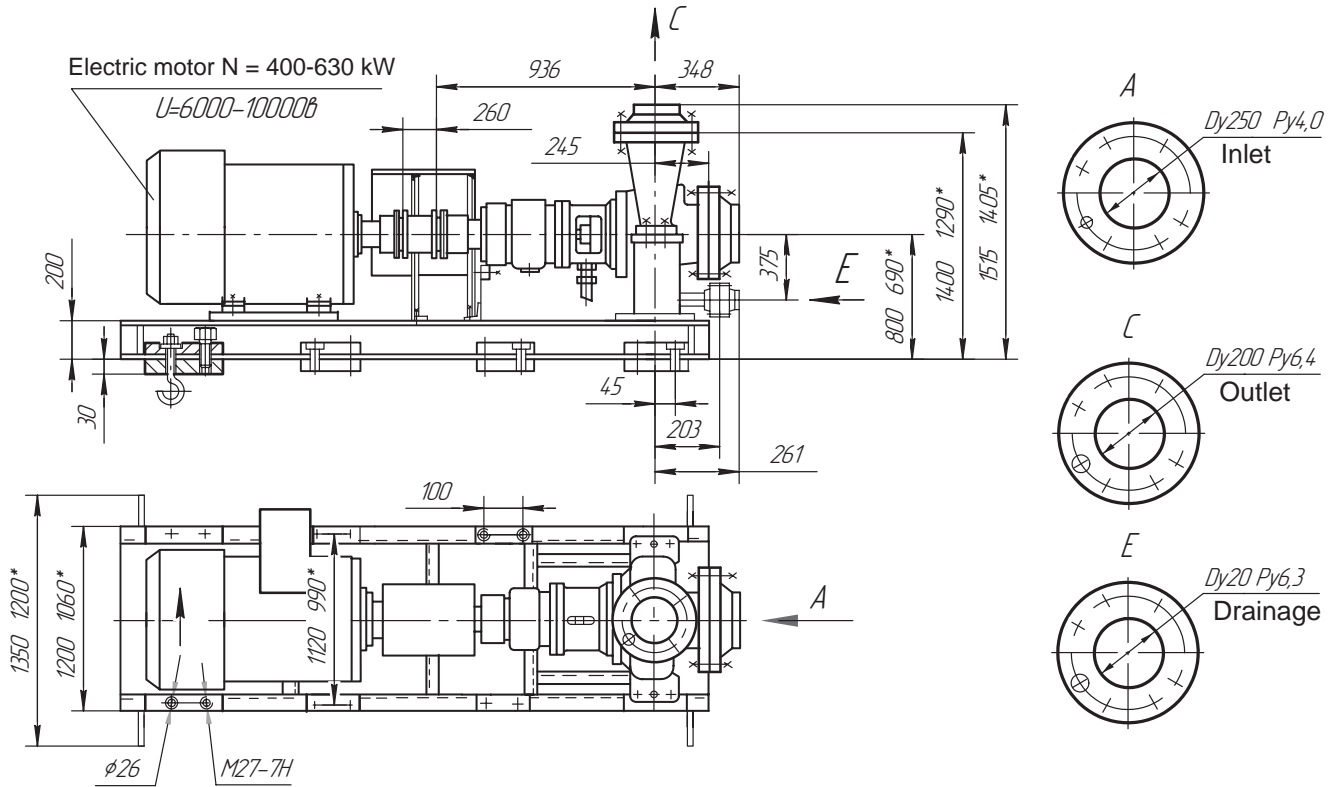

\* Dimensions are indicated for electric motors N=400 kW, U=6000 V

## Cast plate

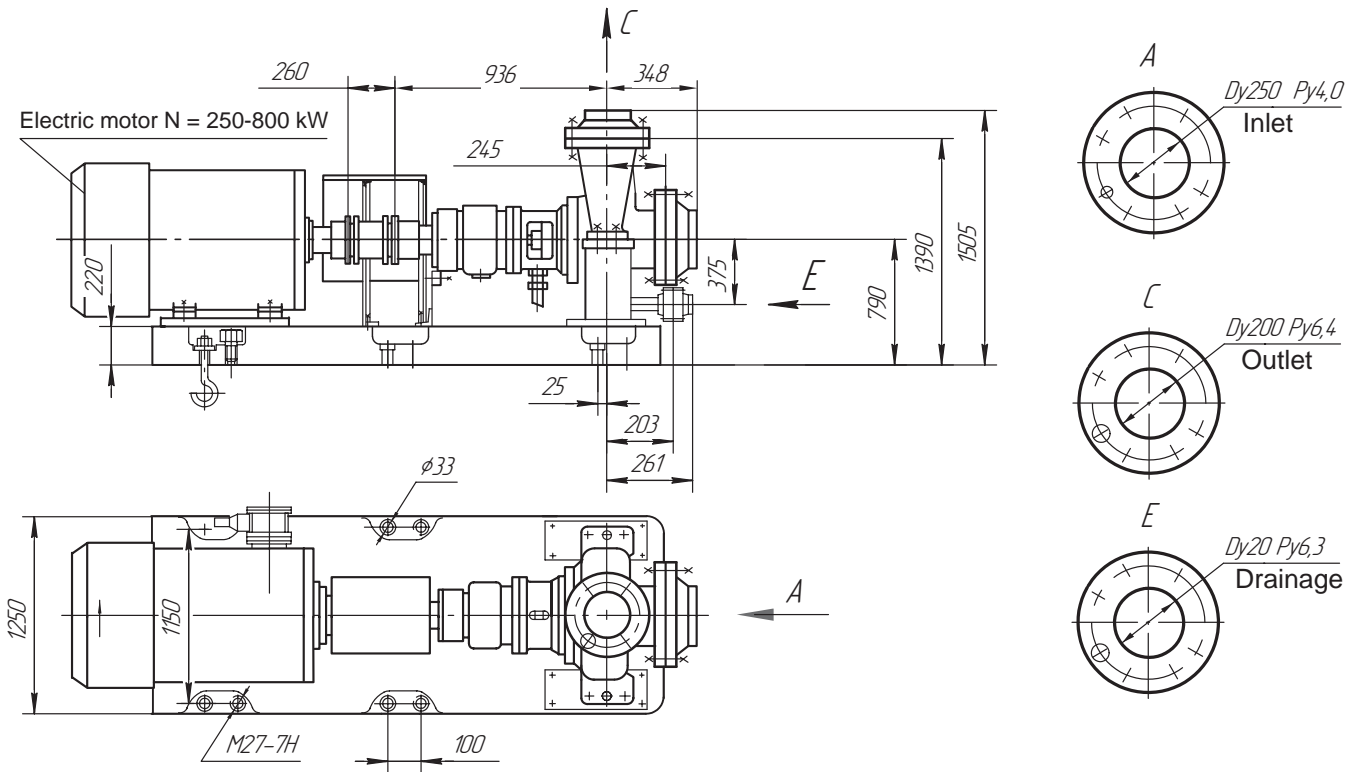

**Note:** Frame (plate) length dimension, quantity and location of holes for foundation bolts subject to clarification for specific type of electric motor.